

ASWP Series

Submersible Sewage Pumps



ASWP11 / ASWP15 / ASWP22 /
ASWP37 / ASWP55

ASWP75 / ASWP75H

AQUATEX ASWP pumps are heavy duty sewage pumps driven by high performance dry type submersible induction motors.

APPLICATIONS

- Transferring raw sewage from collection tank to primary settling tank in sewage treatment plants.



FEATURES

- Dry type submersible induction motor.
- Class 'F' motor insulation.
- Stainless steel shaft and fasteners to enhance life.
- Chemical resistant coating on impeller and casing to improve life and performance.

Non-Clogging

Large channel casing and single vane impeller allow large floating solids to pass through. Can handle solids up to 50 mm in size.

Cable Sealing

Resin filled cable connectors prevent water from entering the motor through the cable wire.

Enhanced Motor Life

Dual mechanical seals prevent water from entering the oil chamber from the pump as well as the dry motor from the oil chamber.

PRODUCT DATA

- Pump range : 1.5HP to 10HP, Three Phase 380V, 50Hz
- Head range : Upto 43m
- Discharge range : Upto 108m³/hr
- Solid handling size : 25mm to 50mm
- Delivery size : 50mm to 100mm

PRODUCT IDENTIFICATION

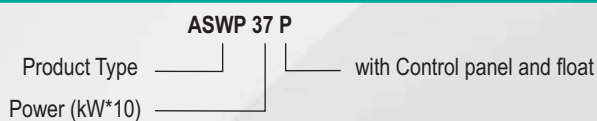

PERFORMANCE CURVE

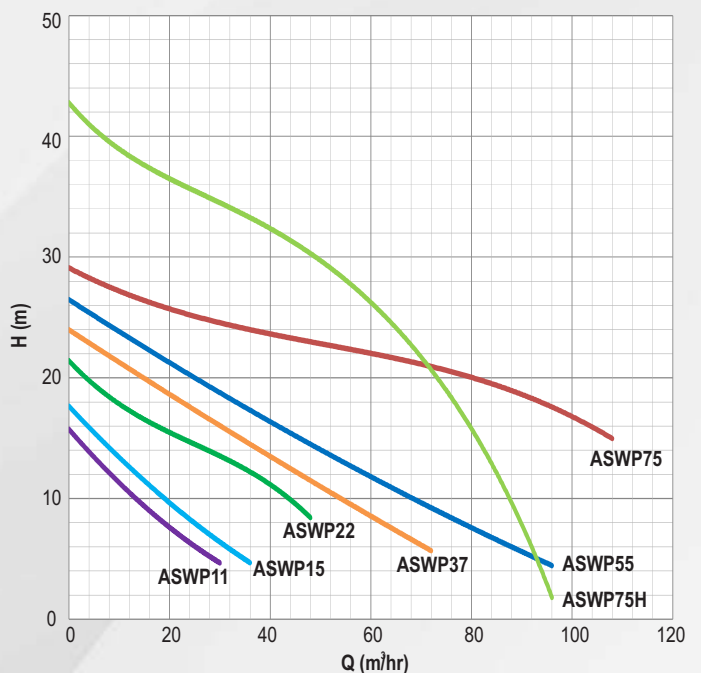

MATERIALS OF CONSTRUCTION

ASWP11 / ASWP15 / ASWP22 / ASWP37 / ASWP55

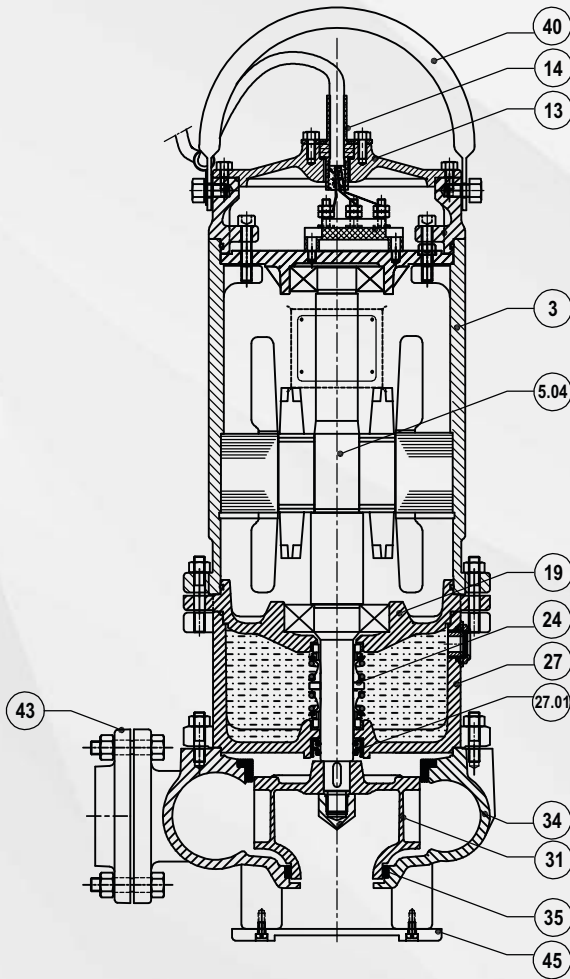

Part No.	Component	Material
3	Stator Body	CI, FG 200
5.04	Motor Shaft	SS, AISI 410
13	Cable Cover	CI, FG 200
14	Cable Bush	Nitrile Rubber
19	Bearing Housing	CI, FG 200
24	Mechanical Seal	Silicon vs Silicon ----- Carbon vs Ceramic
27	Oil Chamber	CI, FG 200
27.01	Lip Seal	SS + Nitrile Rubber
31	Impeller	CI, FG 200
34	Casing	CI, FG 200
35	Wear Ring	Leaded Bronze
40	Handle	SS, AISI 304
43	Delivery Flange	CI, FG 200
45	Casing Plate	CI, FG 200

DIMENSIONS AND WEIGHT

Pump Type	Power		Dimensions (in mm)			Solid Handling size mm	Weight kg
	HP	kW	A	B	ØD		
ASWP11	1.5	1.1	685	281	50	25	66
ASWP15	2.0	1.5	715	306	50	30	94
ASWP22	3.0	2.2	751	347	65	35	99
ASWP37	5.0	3.7	872	413	75	40	147
ASWP55	7.5	5.5	872	413	75	40	150

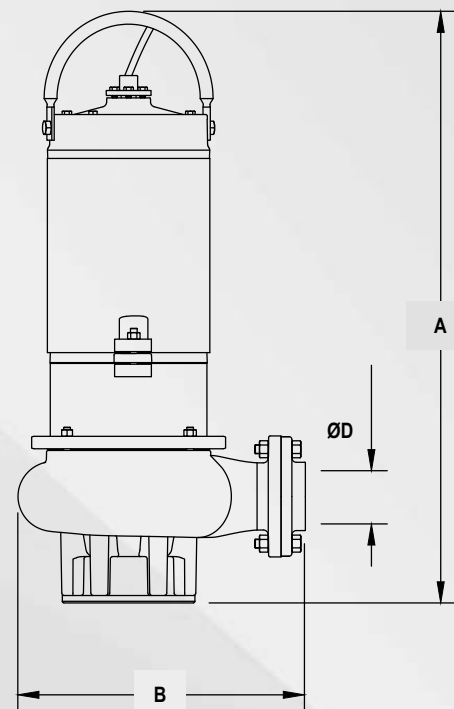

ASWP Series

Submersible Sewage Pumps



MATERIALS OF CONSTRUCTION

ASWP75 / ASWP75H

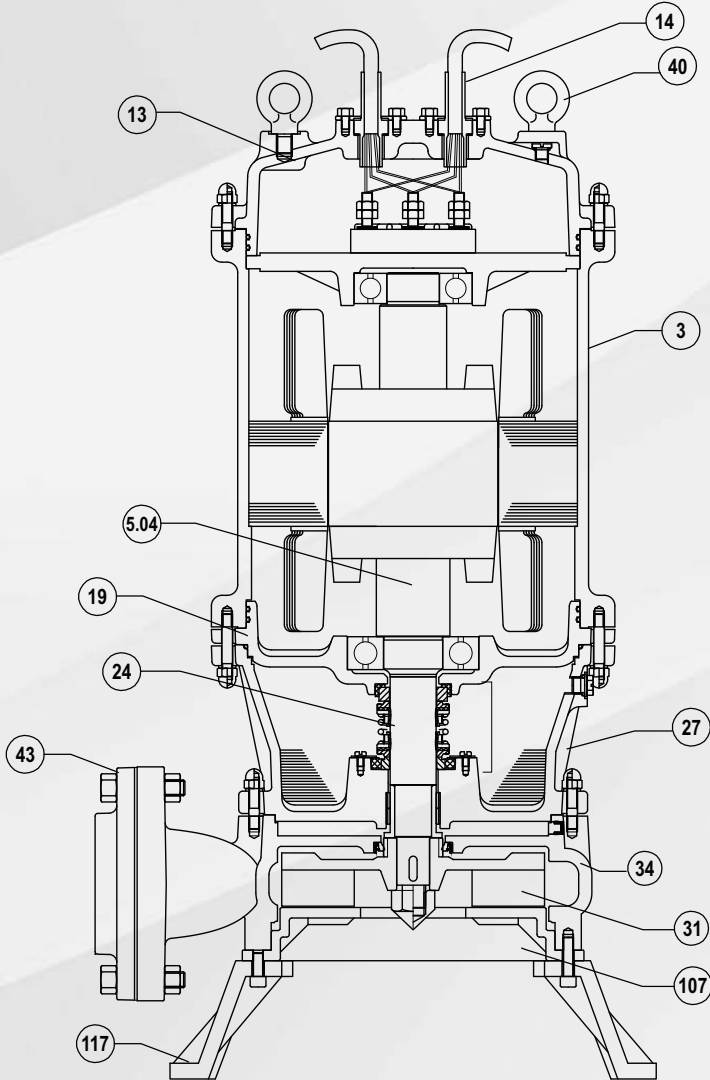

Part No.	Component	Material
3	Stator Body	CI, FG 200
5.04	Motor Shaft	SS, AISI 410
13	Cable Cover	CI, FG 200
14	Cable Bush	Nitrile Rubber
19	Bearing Housing	CI, FG 200
24	Mechanical Seal	Silicon vs Silicon ----- Carbon vs Ceramic
27	Oil Chamber	CI, FG 200
31	Impeller (ASWP75)	CI, FG200
	Impeller (ASWP75H)	SS, CF8
34	Casing	CI, FG 200
40	Eye Bolt	CI, FG 200
43	Delivery Flange	CI, FG 200
107	Wear Plate	CI, FG 200
117	Leg	CI, FG 200

DIMENSIONS AND WEIGHT

Pump Type	Power		Dimensions (in mm)			Solid Handling size	Weight
	HP	kW	A	B	øD	mm	kg
ASWP75	10.0	7.5	825	450	100	50	160
ASWP75H	10.0	7.5	770	390	75	50	155

