



AQUATEX Horizontal Multistage pumps are high performance surface pumps for water transfer.

APPLICATIONS

- Industrial, commercial, and domestic water transfer and pressure boosting applications.
- High pressure washing systems and boiler feed applications.
- Feeder pump for RO Applications.



FEATURES

- Silent operation and low vibration.
- Class "F" motor insulation.
- Impellers, diffusers, stage casings, and shafts are made of corrosion resistant stainless steel.
- Superior hydraulic components for better efficiency.
- Easy to maintain.

PRODUCT DATA

- Power range : 0.5HP to 2HP
Single phase - 220 V, 50 Hz
Three phase - 380 V, 50Hz
- Degree of protection : IP 54
- Discharge range : Upto 7.5 m³/hr
- Head range : Upto 70 m
- Liquid temperature : Max. 80°C
- Suction lift : Max. 7m
- Operating pressure : Max. 7 bar

PRODUCT IDENTIFICATION

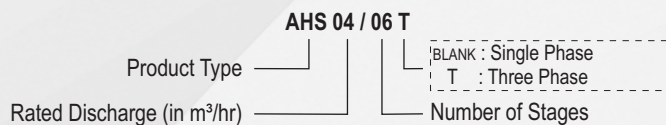

PERFORMANCE CURVE

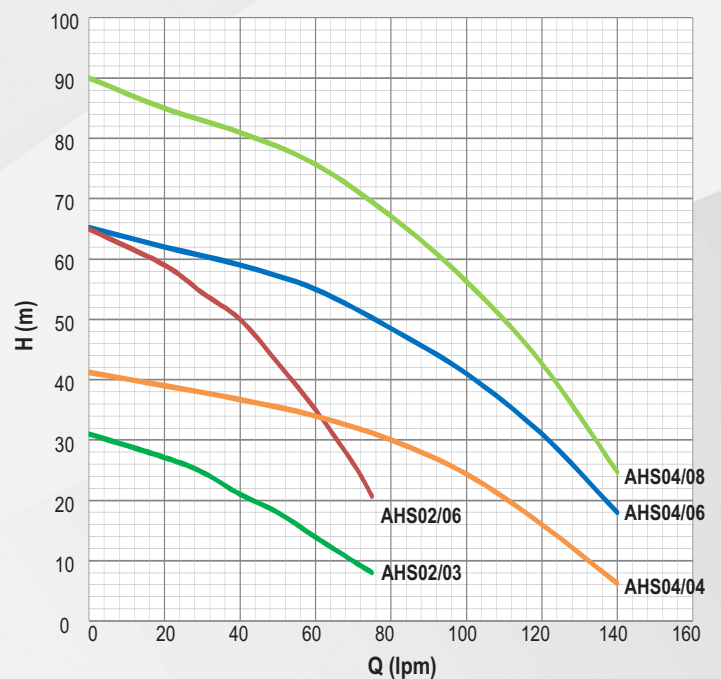

AHS Series

Horizontal Multistage Centrifugal Pumps



MATERIALS OF CONSTRUCTION

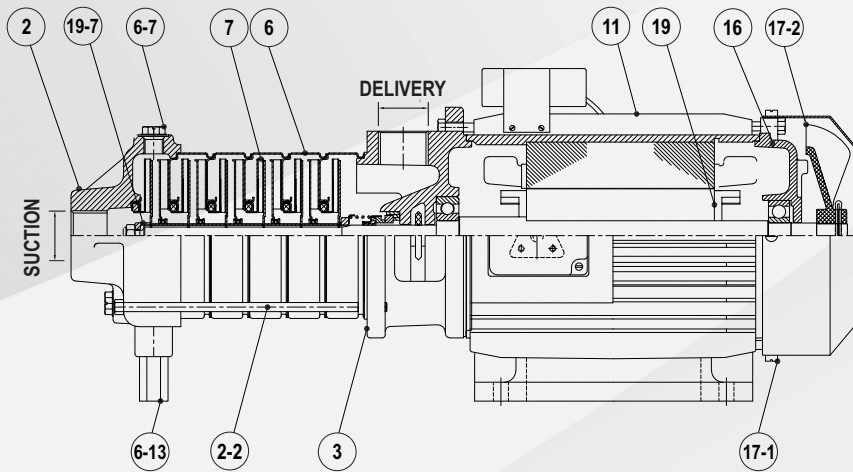

Part No.	Component	Material
2	Suction Bracket	SS, CF8 / CI
2-2	Tie Rod	SS, AISI 304
3	Delivery Bracket	SS, CF8 / CI
6	Stage Casing	SS, AISI 304
6-7	Drain Plug	Brass
6-13	Suction Bracket Leg Support	MS (Zinc Coated)
7	Impeller	SS, AISI 304
11	Stator Frame	CI
16	Back Cover	CI
17-1	Cooling Cover	MS
17-2	Cooling Fan	Plastic
19	Shaft	SS, AISI 410/304
19-7	Bush Sleeve	SS, AISI 304

DIMENSIONS AND WEIGHT

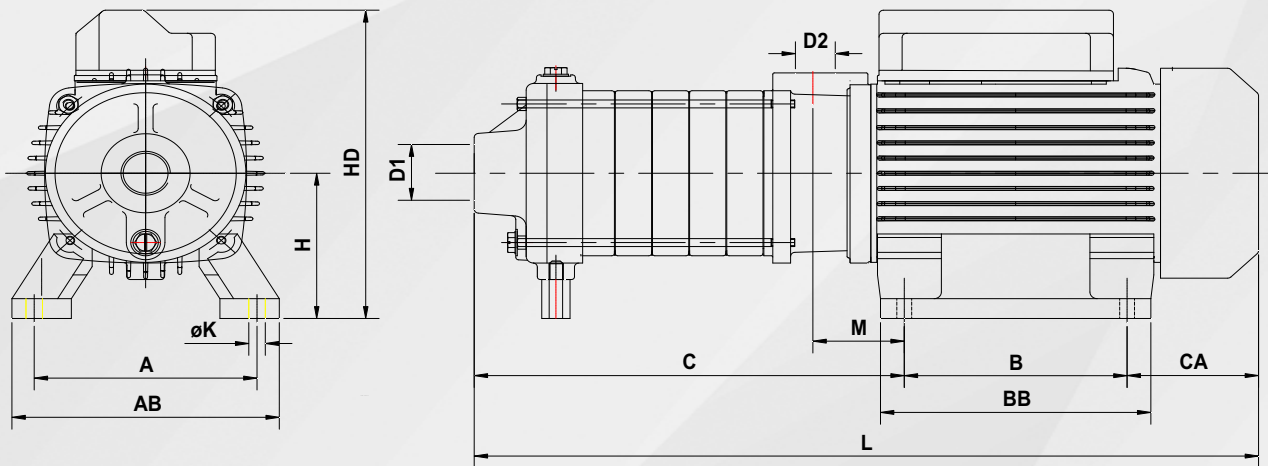

Pump Type	D1	D2	Dimensions (in mm)										Weight	
	mm	mm	A	B	C	H	øK	AB	BB	HD	L	CA	M	kg
AHS02/03	25	25	140	100	202	85	7/16"	168	118	209	376	77	49	19
AHS02/06	25	25	140	145	280	85	7/16"	168	166	209	500	77	51	26
AHS04/04	32	32	140	145	230	85	7/16"	168	166	209	450	77	51	24
AHS04/06	32	32	150	150	290	110	7/16"	180	185	235	530	87	62	34
AHS04/08	32	32	150	180	340	110	7/16"	180	215	235	610	87	62	36